

5V Input 2A/2.8A(Peak) 2.5MHz Synchronous Step-Down Converter

DESCRIPTION

The MT8162 is a 2.5MHz, constant on-time (COT) controlled synchronous step-down converter. It can provide 2A continuous and 2.8A peak output current with input voltage from 2.7V to 6V. The MT8162 output range is from 0.6V to input level, thanks to its 100% duty cycle operation. The constant on-time control scheme simplifies loop compensation and offers excellent load transient response. MT8162 consumes extremely low 25µA quiescent current hence achieves superior light load efficiency. The high gain error amplifier in the control loop provides excellent load and line regulation. Proprietary adaptive on-time helps MT8162 to achieve nearly constant switching frequency across load range. MT8162 has cycle-by-cycle current limit and hiccup mode to protect over-load or short circuit fault conditions.

MT8162 is available in low profile 6 leads SOT563_6L packages.

FEATURES

- Wide Input Range from 2.7V to 6V
- Proprietary Fast Transient Constant On Time Architecture Stable with low ESR Ceramic Output Capacitors
- +/- 1.5% 0.6V Feedback Voltage
- 2.5MHz Switching Frequency
- 25µA Low Quiescent Current
- 2A Continuous and 2.8A Peak Output Current
- 100% Duty Cycle Operation
- Built-in 85mΩ/89mΩ Power Switches
- Internal 0.8msec Soft-Start
- Cycle-by-cycle Current Limit Protection
- Input Under/Over Voltage Lockout
- Output Discharging Function in Shutdown
- Thermal Shutdown Protection
- Hiccup Mode for Short Circuit and Over-Load Protection
- Available in SOT563_6L Package
- Pb-Free RoHS Compliant

APPLICATIONS

- Solid-State and Hard Disk Drives
- WiFi RF Modules
- DC/DC Micro Modules
- Smart Phone and Tablets

TYPICAL APPLICATION

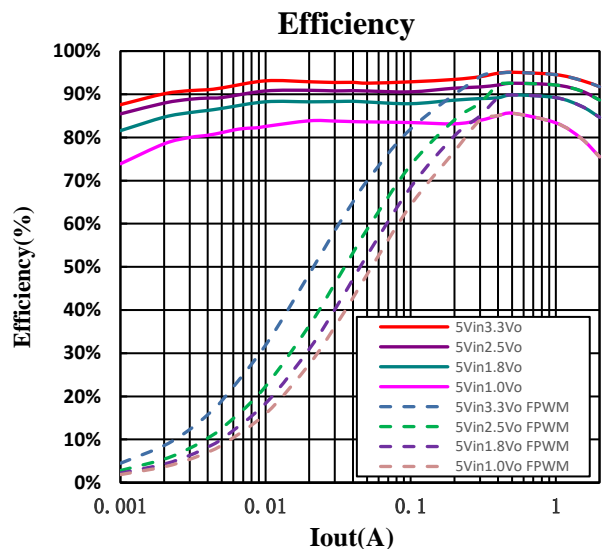
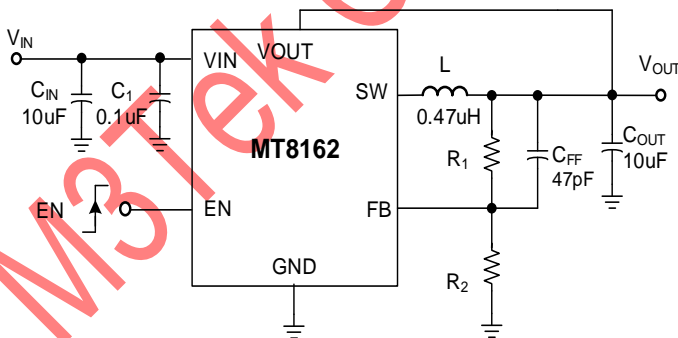

5V Input 2A/2.8A(Peak) 2.5MHz Synchronous Step-Down Converter

Ordering Information

Part No.	Marking	Temp. Range	Remark	Package	MOQ
MT8162NSLR	WNYW	-40°C ~+85°C	Adjustable Vout	SOT563	5000/Tape & Reel
MT8162ASLR	162A YWx	-40°C ~+85°C	Adjustable Vout FPWM Mode	SOT563	5000/Tape & Reel

Note: Y: Year, W: Week, x: Control Code

Pin Configuration

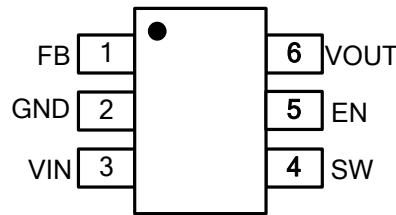

Top View SOT563

Pin Description

Pin Name	SOT563 Pin No.	Description
FB	1	Voltage Feedback Input. Connect a resistor divider between output And FB to program the output voltage. VFB is regulated to 0.6V.
GND	2	Ground.
VIN	3	Input Supply Voltage.
SW	4	Power Switch Node
EN	5	This pin has a pull-down resistor of typically 1MΩ to GND. Drive EN above 1.0V to turn on the converter Drive EN below 0.4V to turn off the converter and discharge output
VOUT	6	Output voltage

5V Input 2A/2.8A(Peak) 2.5MHz Synchronous Step-Down Converter

Application Schematic

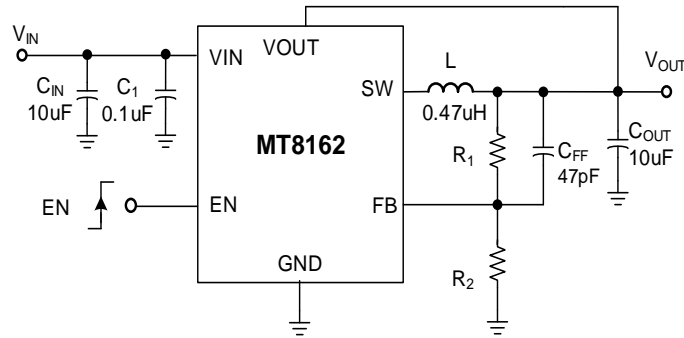

EVB BOM List

Qty	Ref	Value	Description	Package										
1	C _{IN}	10µF	Ceramic Capacitor, 10V, X5R	0805										
1	C _{OUT}	10µF	Ceramic Capacitor, 10V, X5R	0805										
2	C ₁ , C _{EN}	0.1µF	Ceramic Capacitor, 10V, X5R	0603										
1	C _{FF}	47pF	Ceramic Capacitor, 10V, X5R	0603										
1	L	0.47µH	Inductor, MHC106030-R47M, 5.5mΩ, 16.5A	0805 SMD										
1	R ₁	<table border="1"> <tr><td>V_{out}=3.3V</td><td>200KΩ</td></tr> <tr><td>V_{out}=2.5V</td><td>240KΩ</td></tr> <tr><td>V_{out}=1.8V</td><td>200KΩ</td></tr> <tr><td>V_{out}=1.2V</td><td>200KΩ</td></tr> <tr><td>V_{out}=1.0V</td><td>100KΩ</td></tr> </table>	V _{out} =3.3V	200KΩ	V _{out} =2.5V	240KΩ	V _{out} =1.8V	200KΩ	V _{out} =1.2V	200KΩ	V _{out} =1.0V	100KΩ	Resistor, ±1%	0603
V _{out} =3.3V	200KΩ													
V _{out} =2.5V	240KΩ													
V _{out} =1.8V	200KΩ													
V _{out} =1.2V	200KΩ													
V _{out} =1.0V	100KΩ													
1	R ₂	<table border="1"> <tr><td>V_{out}=3.3V</td><td>43KΩ</td></tr> <tr><td>V_{out}=2.5V</td><td>75KΩ</td></tr> <tr><td>V_{out}=1.8V</td><td>100KΩ</td></tr> <tr><td>V_{out}=1.2V</td><td>200KΩ</td></tr> <tr><td>V_{out}=1.0V</td><td>150KΩ</td></tr> </table>	V _{out} =3.3V	43KΩ	V _{out} =2.5V	75KΩ	V _{out} =1.8V	100KΩ	V _{out} =1.2V	200KΩ	V _{out} =1.0V	150KΩ	Resistor, ±1%	0603
V _{out} =3.3V	43KΩ													
V _{out} =2.5V	75KΩ													
V _{out} =1.8V	100KΩ													
V _{out} =1.2V	200KΩ													
V _{out} =1.0V	150KΩ													
1	R _{EN}	100KΩ	Resistor, ±1%	0603										
1	Power IC	MT8162	Step-Down DC/DC Converter	SOT563										

5V Input 2A/2.8A(Peak) 2.5MHz Synchronous Step-Down Converter

Package Information

SOT563 Outline Dimensions

Unit: inches/mm

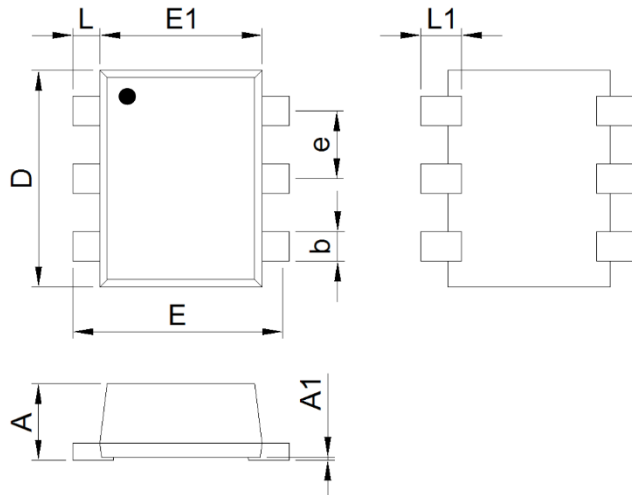

SYMBOLS	MILLIMETERS		INCHES	
	MIN.	MAX.	MIN.	MAX.
A	0.52	0.60	0.021	0.024
A1	0.00	0.05	0.000	0.002
b	0.17	0.27	0.007	0.011
D	1.50	1.70	0.059	0.067
E	1.50	1.70	0.059	0.067
E1	1.10	1.30	0.043	0.051
e	0.45	0.55	0.018	0.022
L	0.10	0.30	0.004	0.012
L1	0.20	0.40	0.008	0.016

5V Input 2A/2.8A(Peak) 2.5MHz Synchronous Step-Down Converter

Tape & Reel Carrier Dimensions

SOT563

1. Orientation / Carrier Tape Information:

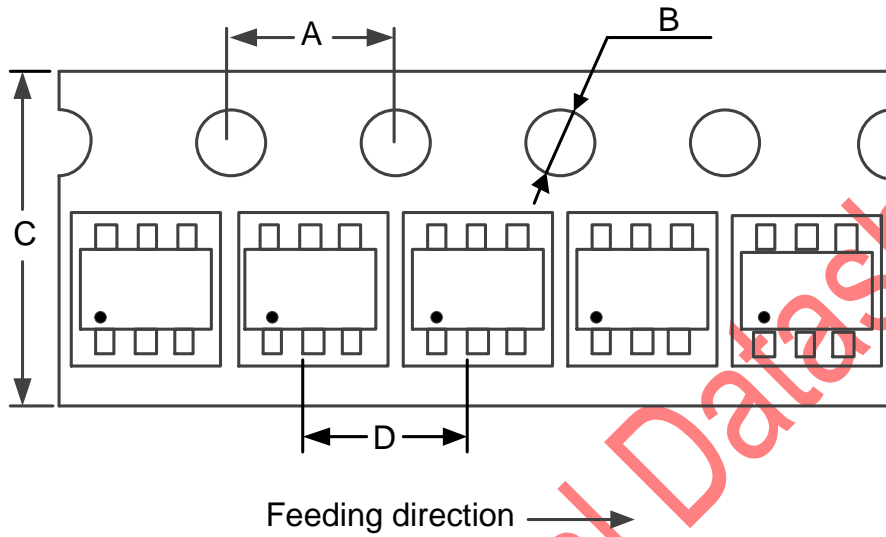

2. Reel Information:

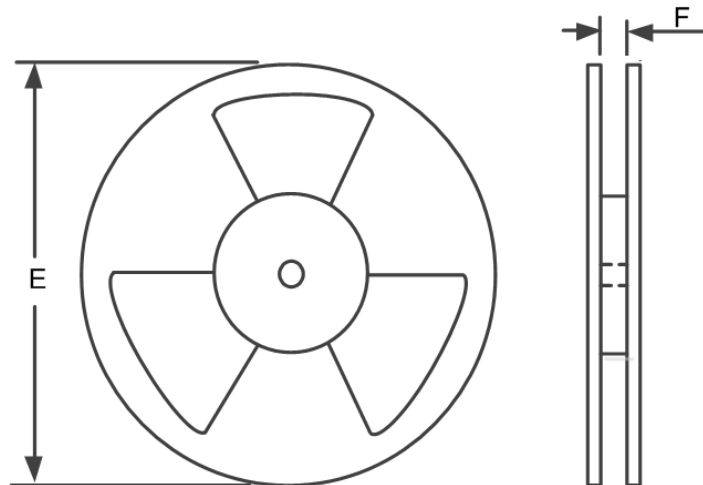

3. Dimension Details:

PKG Type	A	B	C	D	E	F	Q'ty/Reel
SOT563	4.0 mm	1.5mm	8.0mm	4.0mm	7.0inch	9.5mm	5000

5V Input 2A/2.8A(Peak) 2.5MHz Synchronous Step-Down Converter

Reflow Profile

Classification Of IR Reflow Profile

Reflow Profile	Green Assembly
Average Ramp-Up Rate ($T_{s_{min}}$ to T_p)	1~2°C/second, 3°C/second max.
Preheat & Soak	
-Temperature Min($T_{s_{min}}$)	150°C
-Temperature Max($T_{s_{max}}$)	200°C
-Time($t_{s_{min}}$ to $t_{s_{max}}$)	60~120 seconds
Time maintained above:	
-Temperature(T_L)	217°C
-Time(t_L)	60~150 seconds
Peak Temperature(T_p)	See Classification Temp in table 1
Time within 5°C of actual Peak Temperature(t_p)	30 seconds max.
Ramp-Down Rate	6°C/second max.
Time 25°C to Peak Temperature	8 minutes max.

* Tolerance for peak profile Temperature(T_p) is defined as a supplier minimum and a user maximum.

** Tolerance for time at peak profile temperature (t_p) is defined as a supplier minimum and a user maximum.

Table 1. Pb-free Process – Classification Temperatures (T_c)

Package Thickness	Volume mm ³ <350	Volume mm ³ 350-2000	Volume mm ³ >2000
<1.6mm	260°C	260 °C	260°C
1.6mm–2.5mm	260°C	250°C	245°C
2.5mm	250 °C	245°C	245°C

Note: For all temperature information, please refer to top side of the package, measured on the package body surface.

