

2.2MHz 2.7V~5.5V 6A/10A Fast-PWM Synchronous Step-Down Converter

DESCRIPTION

The MT8139 is a 6A/10A high efficiency constant on-time controlled synchronous step-down converter. It operates with input voltage from 2.7V to 5.5V and provides output range from 0.5V to as high as input level, thanks to its 100% duty cycle operation. Its advanced constant on-time control Fast-PWM scheme simplifies loop compensation and offers excellent load transient response while maintaining a relatively constant 2.2MHz switching frequency. The high gain error amplifier in the control loop provides excellent load and line regulation. For fault tolerant operation, MT8139 has cycle-by-cycle current limit protection and hiccup mode for short circuit or over-load condition. MT8139 is available in 14 lead QFN3mmx4mm package and ideal for high performance, portable applications.

FEATURES

- Wide Input Range from 2.7V to 5.5V
- MT8139A: 2.2MHz with Forced PWM Mode (FPWM)
- MT8139_06: 6A Output Current
MT8139_10: 10A Output Current
- High Efficiency up to 97%
- Output Voltage as low as 0.5V
- 100% Duty Cycle Operation
- 0.5%, 0.5V Feedback Voltage Accuracy
- Built-in Ultra Low Ron High Side and Low Side Power Switches
- Cycle-by-cycle Current Limit Protection
- Hiccup Mode for Short Circuit and Over-Load Protection
- Open Drain Power Good Indicator
- Thermal Shutdown Protection
- Stable with low ESR ceramic Output Capacitors
- Available in a Small QFN3mmx4mm_14L Package
- Pb-Free RoHS Compliant

APPLICATIONS

- Fully support Wi-Fi 802.11AX/BE
- Solid-State and Hard Disk Drives
- Portable / Handheld Devices
- Set-top Boxes.
- DC/DC Micro Modules

TYPICAL APPLICATIONS

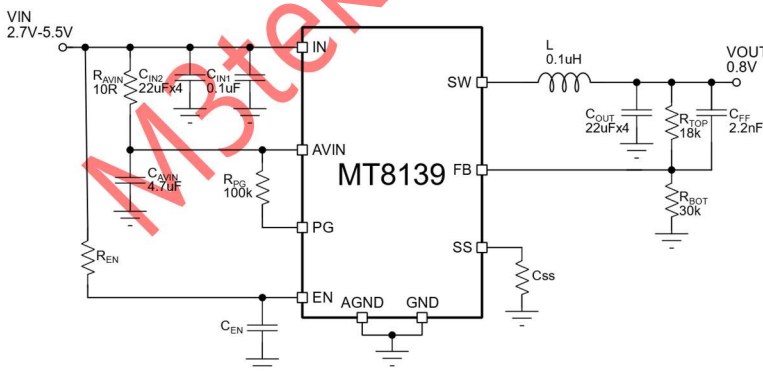

Efficiency VS. IOU

