

Dual 2.5A 1.5MHz High Efficiency Synchronous Step-Down DC/DC Converter

DESCRIPTION

The MT3222 are dual 1.5MHz, 2.5A constant on-time (COT) controlled synchronous step-down converters. MT3222 consumes extremely low 38µA quiescent current hence achieves superior light load efficiency. The 2.5V to 6V input supply range makes the parts ideally suited for single Li-Ion applications. 100% duty cycle capability provides low dropout operation, which extends operating time in battery-operated systems. The constant on-time control scheme simplifies loop compensation and offers excellent load transient response. The high gain error amplifier in the control loop provides excellent load and line regulation. Proprietary adaptive on-time helps MT3222 to achieve nearly constant switching frequency across the continuous conduction load range. MT3222 has cycle-by-cycle current limit and hiccup mode to protect over-load or short circuit fault conditions.

The MT3222 is available in an 8-pin TSOT23 package.

FEATURES

- Dual Outputs operating independently with 2x2.5A Output Current Capability
- Wide Input Range from 2.5V to 6V
- Adjustable Output Voltages from 0.6V to  $V_{IN}$
- Up to 95% High Efficiency
- Proprietary Fast Transient Constant On Time Architecture Stable with low ESR Ceramic Output Capacitors
- 1.5% 0.6V Feedback Voltage
- 1.5MHz Switching Frequency
- 38µA Low Quiescent Current
- 100% Duty Cycle Operation
- $R_{DS(ON)}$  65mΩ HS/ 35mΩ LS @  $V_{IN}=5V$
- Internal 1.5msec Soft-Start
- Cycle-by-cycle Current Limit Protection
- Over-Load and Short Circuit Hiccup Mode
- Output Discharging in Shutdown
- Thermal Shutdown Protection
- Available in a TSOT23\_8L Package
- Pb-Free RoHS Compliant

APPLICATIONS

- Solid-State and Hard Disk Drives
- USB TypeC Dock Station
- Smart Phone and Tablets
- WiFi RF Modules

Typical Applications

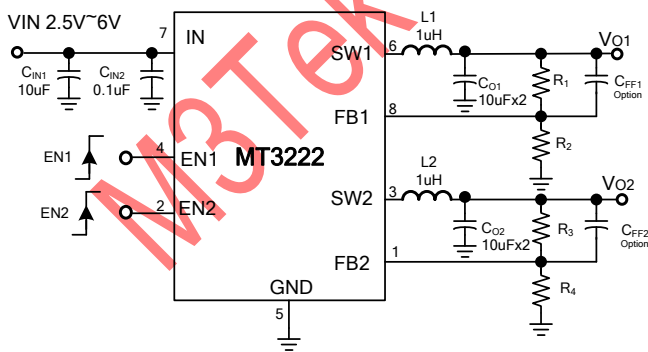

Efficiency

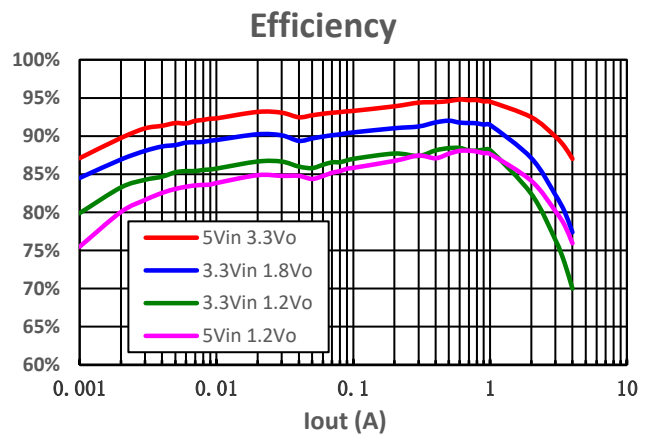

Dual 2.5A 1.5MHz High Efficiency Synchronous Step-Down DC/DC Converter

Ordering Information

Part No.	Marking	Temp. Range	Package	MOQ
MT3222NTPCR	3222 YWWxx	-40°C ~+85°C	TSOT23_8L	3000/Tape & Reel

Note: Y:Year, W:Week, x:Manufacture Code

Pin Configuration

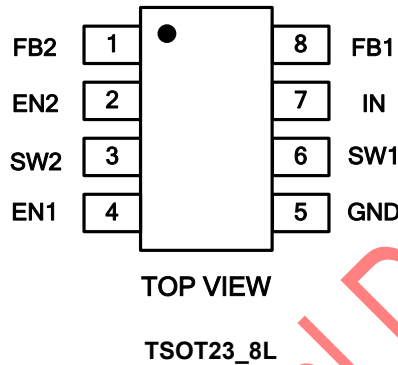

Pin Description

Pin No.	Symbol	Description
1	FB2	Channel 2(CH2) Voltage Feedback Input. Connect a resistor divider between channel Output and FB2 to program the output voltage. VFB2 is regulated to 0.6V.
2	EN2	<b>Channel 2 Enable</b> Control Input with accurate 1.21V enable threshold which can be used to build precision R-C turn-on delay and input under-voltage lockout. This pin has a pull-down resistor of typically 1MΩ to GND. <ul style="list-style-type: none"> <li>• Drive EN above 1.21V to turn on the converter</li> <li>• Drive EN below 1.1V to turn off the converter and discharge output</li> </ul>
3	SW2	Channel 2 Power Switch Node. Connect SW2 to an inductor.
4	EN1	<b>Channel 1 Enable</b> Control Input with accurate 1.21V enable threshold which can be used to build precision R-C turn-on delay and input under-voltage lockout. This pin has a pull-down resistor of typically 1MΩ to GND. <ul style="list-style-type: none"> <li>• Drive EN above 1.21V to turn on the converter</li> <li>• Drive EN below 1.1V to turn off the converter and discharge output</li> </ul>
5	GND	Ground
6	SW1	Channel 1 Power Switch Node. Connect SW1 to an inductor.
7	IN	Channel 1 and Channel 2 Input Supply Voltage.
8	FB1	Channel 1(CH1) Voltage Feedback Input. Connect a resistor divider between channel Output and FB1 to program the output voltage. VFB1 is regulated to 0.6V.