

5V Input 4A 1.5MHz Synchronous Step-Down DC/DC Converter

DESCRIPTION

The MT3068 is a 1.5MHz, 4A constant on-time (COT) controlled synchronous step-down converter. It can operate with input voltage from 2.5V to 5.5V and provide output range from 0.6V to input level, thanks to its 100% duty cycle operation. The constant on-time control scheme simplifies loop compensation and offers excellent load transient response. MT3068 consumes extremely low 15µA quiescent current hence achieves superior light load efficiency. The high gain error amplifier in the control loop provides excellent load and line regulation. Proprietary adaptive on-time helps MT3068 to achieve nearly constant switching frequency across load range. MT3068 has cycle-by-cycle current limit and hiccup mode to protect over-load or short circuit fault conditions. MT3068 is available in low profile 10 leads DFN 3mm x 3mm packages.

FEATURES

- Wide Input Range from 2.5V to 6V
- Proprietary Fast Transient Constant On Time Architecture Stable with low ESR Ceramic Output Capacitors
- +/- 2% 0.6V Feedback Voltage
- 1.5MHz Switching Frequency
- 15µA Low Quiescent Current
- 4A Output Current
- 1.21V Accurate Enable Threshold
- Up to 95% Efficiency
- 100% Duty Cycle Operation
- Built-in 80mΩ/50mΩ Power Switches
- Internal 1msec Soft-Start
- Cycle-by-cycle Current Limit Protection
- Over-Load and Short Circuit Hiccup Mode
- Open Drain Power Good Indication
- Output Discharge
- Thermal Shutdown Protection
- Available in Small DFN3X3_10L
- Pb-Free RoHS Compliant

APPLICATIONS

- Solid-State and Hard Disk Drives
- WiFi RF Modules
- Smart Phone and Tablets
- DC/DC Micro Modules

Typical Applications

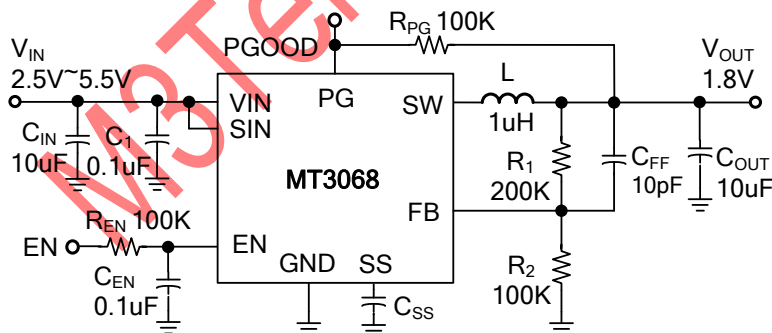

Efficiency

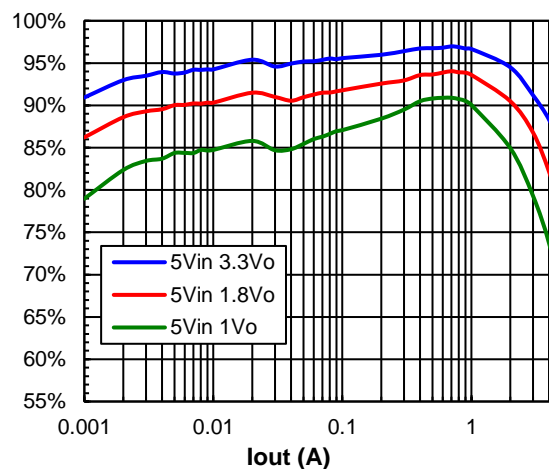

5V Input 4A 1.5MHz Synchronous Step-Down DC/DC Converter

Ordering Information

Part No.	Marking	Temp. Range	Package	MOQ
MT3068NDCR	MT3068 YWWxx	-40°C ~+85°C	DFN3X3_10L	5000/Tape & Reel

Note: Y:Year, W:Week, xx:Manufacture Code

Pin Configuration

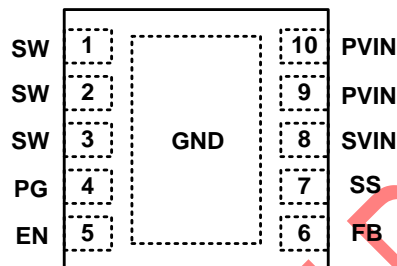

EXPOSED PAD ON BACKSIDE

Top View

Pin Description

Pin No.	Symbol	Description
1~3	SW	Power Switch Node
4	PG	Power Good Open-drain Output. Connect a 100kΩ pull-up resistor to V_{IN} or V_{OUT} .
5	EN	Regulator Enable Control Input with accurate 1.21V enable threshold which can be used to build precision R-C turn-on delay and input under-voltage lockout. Don't float this pin. This pin has an pull-down resistor of typically 1MΩ to GND. <ul style="list-style-type: none"> • Drive EN above 1.21V to turn on the converter • Drive EN below 1.11V to turn off the converter and discharge output
6	FB	Voltage Feedback Input. Connect a resistor divider between output and FB to program the output voltage. VFB is regulated to 0.6V.
7	SS	Soft-start programming pin, connect a capacitor from this pin to ground to program the soft-start time. As MT3068 also has internal 1ms soft-start, the actual soft-start time will be the longer one of the programmed value and the internal value. $T_{SS} = \text{Max}(1\text{ms}, 0.6V \cdot C_{SS} / 2\mu A)$
8	SVIN	Signal Input Supply Voltage
9,10	PVIN	Power Input Supply Voltage
EP	GND	Power ground